

Monitoring Indicators of International Guidance Documents and Frameworks through LADM

Abdullah Kara, Mengying Chen, Peter van Oosterom and Christiaan Lemmen
26th September 2024

12th International FIG Workshop on LADM & 3D LA
24-26 September 2024, Kuching, Malaysia



Content

- Introduction
- Land Governance Assessment Framework (LGAF)
- Global Land Indicators (GLI)
- Monitoring indicators through LADM Edition II
- Conclusion

Introduction

- The evaluation of the **performance of a land administration system (LAS)** is an important task, as it may identify the **strengths** and **weaknesses** of the existing system and provide the **basis for improving** it.
- Efforts have been made to develop **frameworks for evaluating** and comparing the **performance of LASs**. Global initiatives such as the **World Bank**, the **United Nations (UN)** (e.g., **UN-Habitat**, **UN-GGIM**, **FAO**) and the **Global Land Tool Network (GLTN)** have published agendas, guidelines and frameworks that focus on evaluating LASs.

Land Governance Assessment Framework (LGAF)

- Published by the World Bank in 2013
- Motivation: land policy analysis and interventions are often fragmented
- Aim: identify and monitor good practices in the land sector
- Five key thematic areas of LGAF
 - how land rights are defined and enforced,
 - how land is managed, used and taxed,
 - how public land is managed,
 - how information on rights is maintained and accessed,
 - how land disputes are managed and resolved

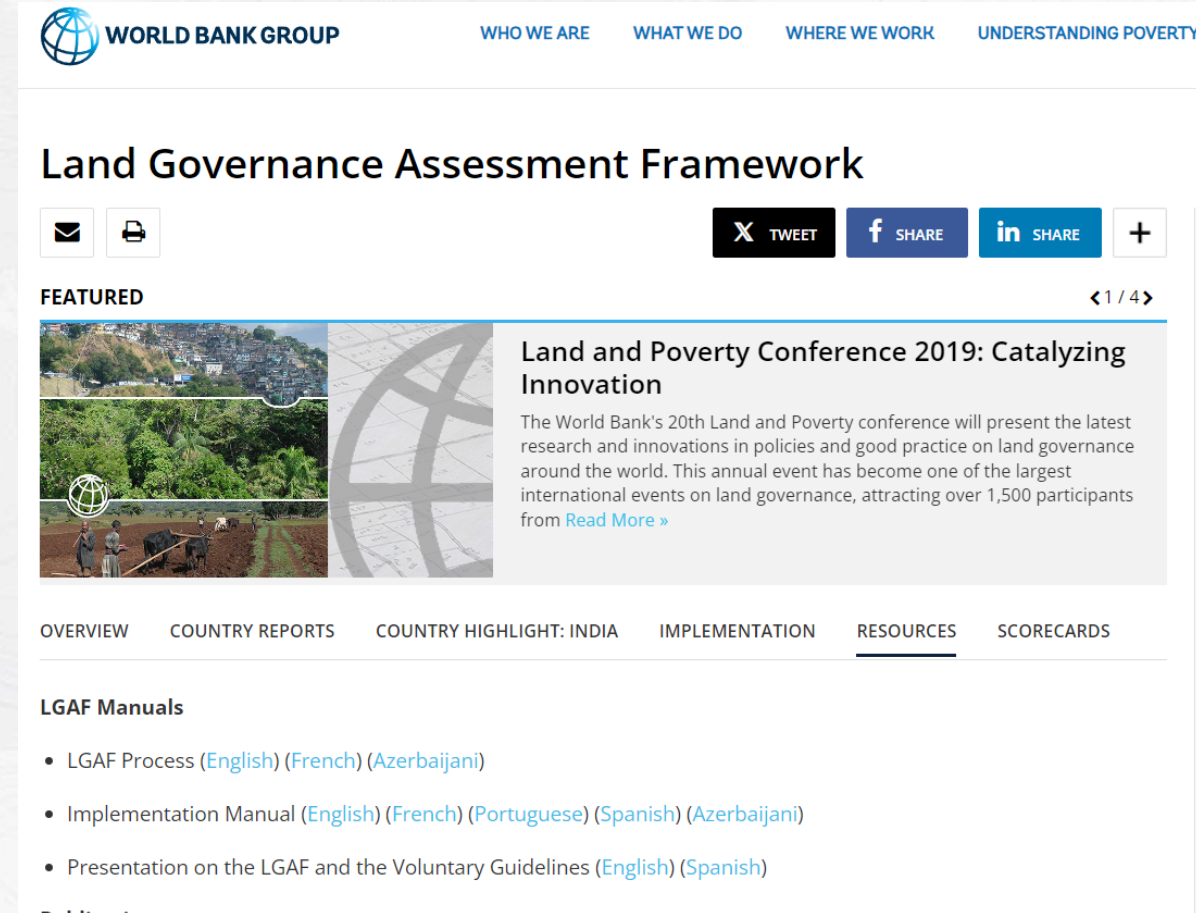

The screenshot shows the World Bank Group website for the Land Governance Assessment Framework. The header includes the World Bank Group logo and navigation links: WHO WE ARE, WHAT WE DO, WHERE WE WORK, and UNDERSTANDING POVERTY. The main heading is "Land Governance Assessment Framework". Below the heading are icons for email, print, and social media sharing (Twitter, Facebook, LinkedIn, and a plus sign). A "FEATURED" section is visible, with a navigation arrow indicating 1 of 4 items. The featured item is "Land and Poverty Conference 2019: Catalyzing Innovation", with a sub-heading and a brief description: "The World Bank's 20th Land and Poverty conference will present the latest research and innovations in policies and good practice on land governance around the world. This annual event has become one of the largest international events on land governance, attracting over 1,500 participants from [Read More >](#)". Below the featured section are navigation tabs: OVERVIEW, COUNTRY REPORTS, COUNTRY HIGHLIGHT: INDIA, IMPLEMENTATION, RESOURCES, and SCORECARDS. The "RESOURCES" tab is selected. Under "RESOURCES", there is a section for "LGAF Manuals" with three items: "LGAF Process" (English, French, Azerbaijani), "Implementation Manual" (English, French, Portuguese, Spanish, Azerbaijani), and "Presentation on the LGAF and the Voluntary Guidelines" (English, Spanish).

Land Governance Assessment Framework (LGAF)

- The LGAF was developed by the **World Bank** in partnership with **FAO, UN-Habitat, International Fund for Agricultural Development (IFAD), International Food Policy Research Institute (IFPRI), the African Union**, and bilateral partners (World Bank, 2024)
- It is worth noting that the LGAF has been revised to take into account the **VGGTs** and the lessons learned from the implementation of the LGAF.



Land Governance Assessment Framework (LGAF)

- The LGAF process is coordinated and implemented by **country experts**
- Between **3 and 8 members** can be selected for **each panel** to bring together a variety of perspectives and substantive expertise needed to provide a meaningful assessment. **9 panels** are:
 - land tenure recognition,
 - rights to forest and common lands & rural land use regulations,
 - urban land use, planning, and development,
 - public land management,
 - transparent process and economic benefit,
 - public provision of land information: registry and cadastre,
 - land valuation and taxation,
 - dispute resolution,
 - review of institutional arrangements and policies
- The implementation manual of the LGAF identifies **27 main indicators, associated with 108 dimensions.**

Land Governance Assessment Framework (LGAF)

PANEL 1. LAND TENURE RECOGNITION		
LGI	Dim.	<i>Land Governance Indicator 1. Recognition of a continuum of rights: the law recognizes a range of rights by individuals (incl. secondary rights, rights by minorities and women)</i>
1	1	INDIVIDUAL RURAL LAND TENURE RIGHTS ARE LEGALLY RECOGNIZED. A: Existing legal framework recognizes and protects rights held by more than 90% of the rural population. B: Existing legal framework recognizes and protects rights held by 70% - 90% of the rural population C: Existing legal framework recognizes and protects rights held by 50% -70% of the rural population D: Existing legal framework recognizes and protects rights held by less than 50% of the rural population
1	2	CUSTOMARY TENURE RIGHTS ARE LEGALLY RECOGNIZED. A: Recognition and effective protection of all customary rights B: Recognition of customary rights but only partly protected C: Partly Recognition of customary rights, which are protected D: Customary rights are not recognized and not protected
1	3	INDIGENOUS RIGHTS TO LAND AND NATURAL RESOURCES ARE LEGALLY RECOGNIZED AND PROTECTED IN PRACTICE, WHERE RELEVANT ACCORDING TO INTERNATIONAL TREATIES. A: Recognition and effective protection of all indigenous rights B: Recognition of indigenous rights but only partly protected C: Partly Recognition of indigenous rights, which are protected D: indigenous rights are not recognized and not protected
1	4	URBAN LAND TENURE RIGHTS ARE LEGALLY RECOGNIZED. A: Existing legal framework recognizes rights held by more than 90% of the urban population B: Existing legal framework recognizes rights held by 70% - 90% of the urban population C: Existing legal framework recognizes rights held by 50% -70% of the urban population D: Existing legal framework recognizes rights held by less than 50% of the urban population

Source: LGAF implementation manual (World Bank, 2013)

Land Governance Assessment Framework (LGAF)



AFRICA

Burkina Faso
[Final Report \(French\)](#) | [Summary \(English\)](#)

Burundi
[Final Report \(French\)](#) | [Scorecard](#)

Cameroon
[Final Report \(French\)](#) | [Scorecard](#)

Cote d'Ivoire
[Final Report \(French\)](#) | [Scorecard](#)

Dem. Republic of the Congo
[Final Report \(French\)](#) | [Scorecard](#)

Ethiopia
[Final Report](#) | [Scorecard](#) | [Policy](#)

Gambia
[Final Report](#) | [Synthesis Report](#)

Ghana
[Final Report](#) | [Synthesis Report](#)

Guinea
[Final Report \(French\)](#) | [Scorecard](#)

Kenya
[Final Report](#) | [Scorecard](#) | [Policy](#)

Madagascar
[Final Report \(French\)](#) | [Synthesis Report](#)

Malawi
[Final Report](#) | [Synthesis Report](#)

Mauritania
[Final Report \(French\)](#) | [Synthesis Report \(French\)](#)
[Fonciere en Mauritanie](#)

Mozambique
[Final Report \(Portuguese\)](#)

Nigeria
[Final Report](#) | [Synthesis Report](#)

Rwanda
[Final Report](#) | [Scorecard](#)

Senegal
[Final Report \(French\)](#) | [Synthesis Report](#)

Sierra Leone
[Final Report](#) | [Scorecard](#)

South Africa
[Final Report](#) | [Synthesis Report](#)

South Sudan
[Final Report](#) | [Synthesis Report](#)

Tanzania
[Final Report](#) | [Scorecard](#)

Uganda
[Final Report](#) | [Scorecard](#)

Zambia
[Final Report](#) | [Scorecard](#)

ASIA

Afghanistan
[Final Report](#) | [Scorecard](#)

India
[National Synthesis Report](#)

Indonesia
[Book Chapter](#) | [Final Report](#)

Philippines
[Final Report](#) | [Synthesis Report](#)

Vietnam
[Final Report](#) | [Executive Summary](#)

EUROPE AND CENTRAL ASIA

Croatia
[Final Report](#) | [Scorecard](#) | [Policy Map](#)

Georgia
[Final Report](#) | [Executive Summary](#)

Kyrgyz Republic
[Book Chapter](#)

Moldova
[Final Report](#) | [Final Report \(Romanian\)](#)

Ukraine
[Final Report](#) | [Policy Brief](#) | [Policy Brief](#)

LATIN AMERICA

Brazil
[Final Report](#) | [Final Report \(Portuguese\)](#) | [State of the Sector](#)

Colombia
[Final Report \(Spanish\)](#)

Guatemala
[Final Report \(Spanish\)](#)

Honduras
[Final Report \(Spanish\)](#)

Peru
[Final Report \(Spanish\)](#)

Source: <https://www.worldbank.org/en/programs/land-governance-assessment-framework#2>



tion



Global Land Indicators (GLI)

- Published by the **Global Land Indicators Initiative (GLII)** established under the **Global Land Tool Network (GLTN)** in 2012
- GLII was established by the **Millennium Challenge Corporation, the World Bank, and UN-Habitat.**
- Aim: to **harmonize monitoring efforts** around **land tenure and governance**. The GLII seeks to derive a **list of globally comparable harmonized land indicators**.



The screenshot shows the GLTN website header with the logo and navigation menu. Below the menu, there are several news items with small images and text. The main content area features the title 'Global Land Indicators Initiative (GLII)' and a sub-header 'Developing a common framework for tracking progress on land issues.' Below this, there are buttons for 'ABOUT THE INITIATIVE', 'KEY DOCUMENTS', and 'MORE INFORMATION'. On the right side, there is a logo for 'LAND AND THE SUSTAINABLE DEVELOPMENT GOALS (SDGS)'.

Global Land Indicators (GLI)

- GLII includes over 50 institutions around the world ranging from **UN Agencies, inter-governmental organizations, international nongovernmental organizations, academia, private sector, researchers and training institutions, and farmer organizations**
- GLII is in relation with global and regional land governance frameworks: the **VGGTs**, the **SDGs**, the **NUA**, the **African Union Framework and Guidelines for Land Policy in Africa (AU-F&G)**.

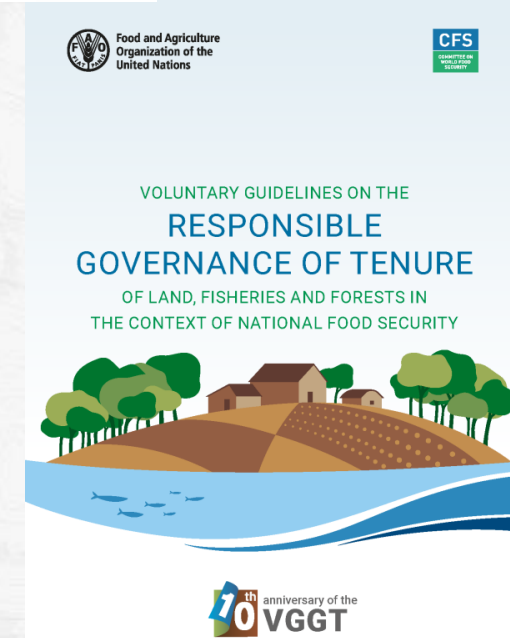
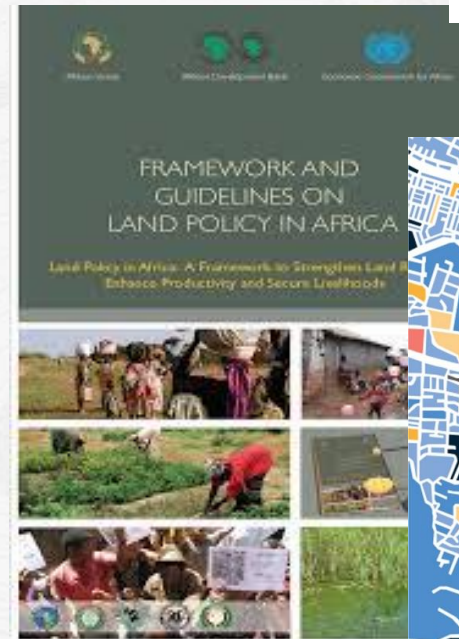

Global Land Indicators (GLI)

- In 2021, UN-Habitat and GLTN published an **assessment document** to “**better understand how GLII land indicators are being used** by GLII partner and non-partner organizations”

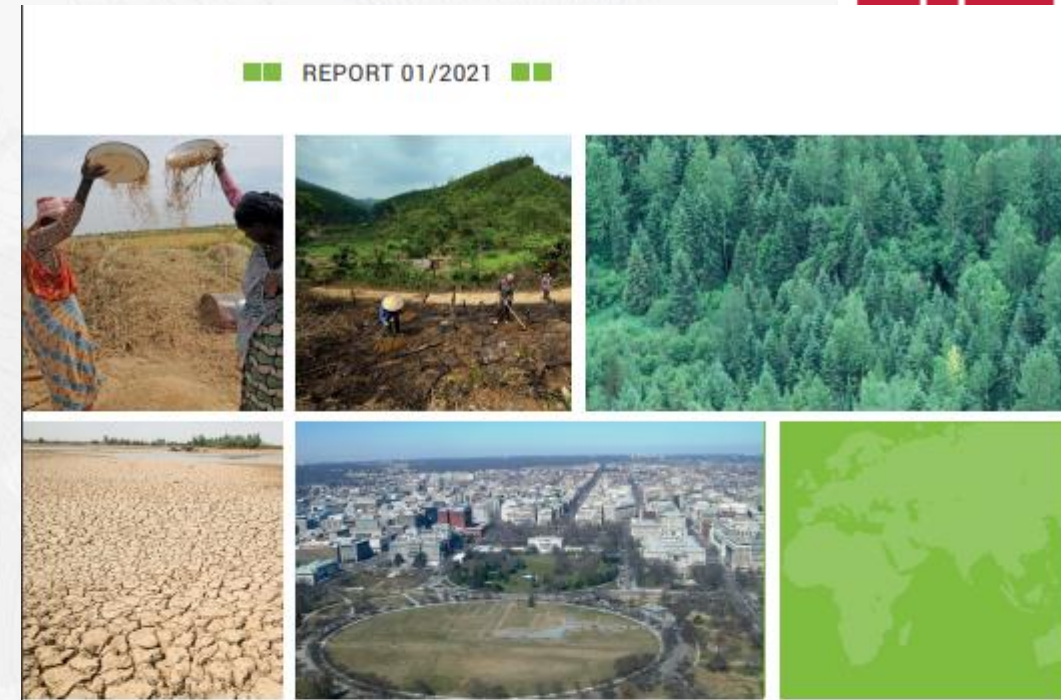

ASSESSMENT OF THE UPTAKE OF THE SET OF 15 INDICATORS BY GLOBAL LAND INDICATORS INITIATIVE IN GLOBAL AND REGIONAL FRAMEWORKS AND BY LAND ACTORS

Table 1: GLII Indicators

Indicator Number	List of Indicators
Land Tenure Security	
Indicator 1.1	Documented land rights
Indicator 1.2	Perceived tenure security
Indicator 1.3	Tenure security under a plurality of tenure regimes
Indicator 1.4	Equal rights of women
Indicator 1.5	Indigenous land rights
Land Tenure Conflicts and Disputes	
Indicator 2.1	Percentage of women and men, Indigenous Peoples and local communities who have experienced land, housing or property disputes or conflict
Indicator 2.2	Availability of dispute-resolution mechanisms
Indicator 2.3	Land dispute-resolution effectiveness
Land Administration Services	
Indicator 3.1	Land administration efficiency
Indicator 3.2	Transparency of land information: level to which land information is available for public access
Indicator 3.3	Land administration availability
Indicator 3.4	Mobilization of land-based taxes
Indicator 3.5	Land area mapped
Sustainable Land Use	
Indicator 4.1	Aggregate national changes in land-use sustainability
Indicator 4.2	Progress in sustainable land-use planning

Source:
<https://unhabitat.org/sites/default/files/2021/09/assessment-of-the-uptake-of-the-set-of-15-indicators-by-glii.pdf>

LADM Edition II

- Lemmen et al. (2019) published a paper specifying the planned extension, based on the several meetings, to LADM.

Moreover, a foundation for a Land Administration Performance Index is included in Edition II – which is possible linked to existing global frameworks or initiatives.

The Global Land Indicators Initiative, (see UN Habitat/GLTN, 2017; UN ECOSOC and African Union 2016), seeks to derive a list of globally comparable harmonized land indicators, using existing monitoring mechanisms and data collection methods as a foundation. Internationally agreed standards will be key component alongside agreed global concepts and evidence-based approaches. There is a need for a foundation of a Land Administration Performance Index – which is a possible link to existing global frameworks or initiatives.

LADM Edition II

- Since the LADM Edition II provides full support for **all the functions of the LA**, it can also be used to evaluate the value and use of land-related indicators.
- **Interface classes to the LADM** can be created to support the monitoring performance of indicators of World Bank and GLII.



Monitoring indicators through LADM Edition II

Bridging Sustainable Development Goals and Land Administration: The Role of the ISO 19152 Land Administration Domain Model in SDG Indicator Formalization †

by Mengying Chen ^{1,*} , Peter Van Oosterom ¹  , Eftychia Kalogianni ¹  , Paula Dijkstra ²  and Christiaan Lemmen ³  

- In this study, the categorization proposed Chen et al. (2024) is used
- The indicators of LGAF and GLI highlighted in in **green** represent **full computational association** with LADM, while **turquoise** represents **partial computational association**. **Indirect association** is shown in **yellow**, **association with other standards** is shown in **pink**, and **non-association** is shown in **gray**.

Monitoring indicators through LADM Edition II

**LGAF / 2. Respect for
and enforcement of rights
(2.2+2.3)**

Individually held land in rural areas is formally registered.

Individually held land in urban areas is formally registered.

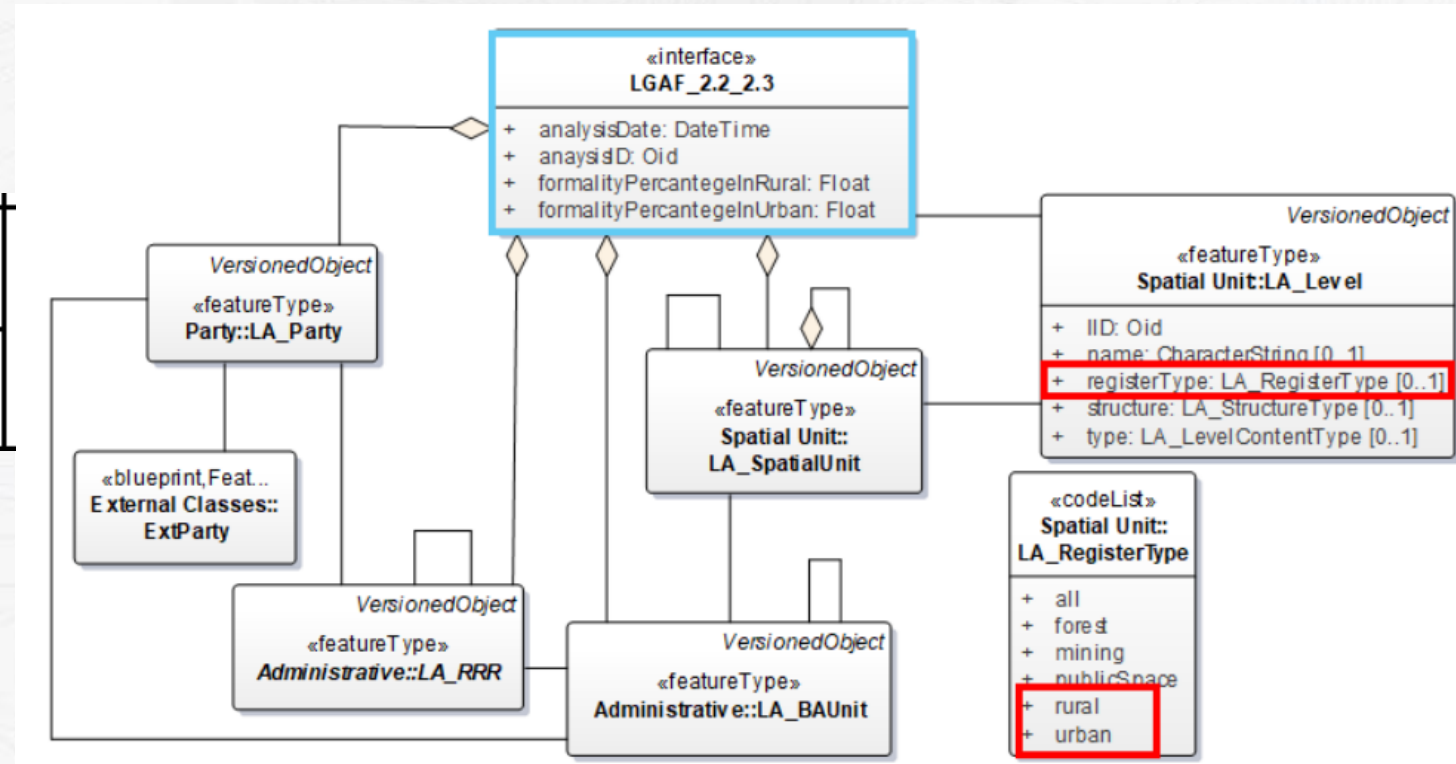

ISO 19152-1 + ISO 19152-2

Monitoring indicators through LADM Edition II



LGAF / 2. Respect for and enforcement of rights (2.5+2.6)

Women's rights are registered and recognized in practice in both urban and rural areas.

Women's property rights to land are equal to those by men.

GLI / (1.1 + 1.4)

Indicator 1.1 Documented land rights	Percentage of women and men with legally recognized documentation and evidence of secure rights to land.
Indicator 1.4 Equal rights of women	Level to which women and men have equal rights to land, including rights to use, control, own, inherit and transact these rights

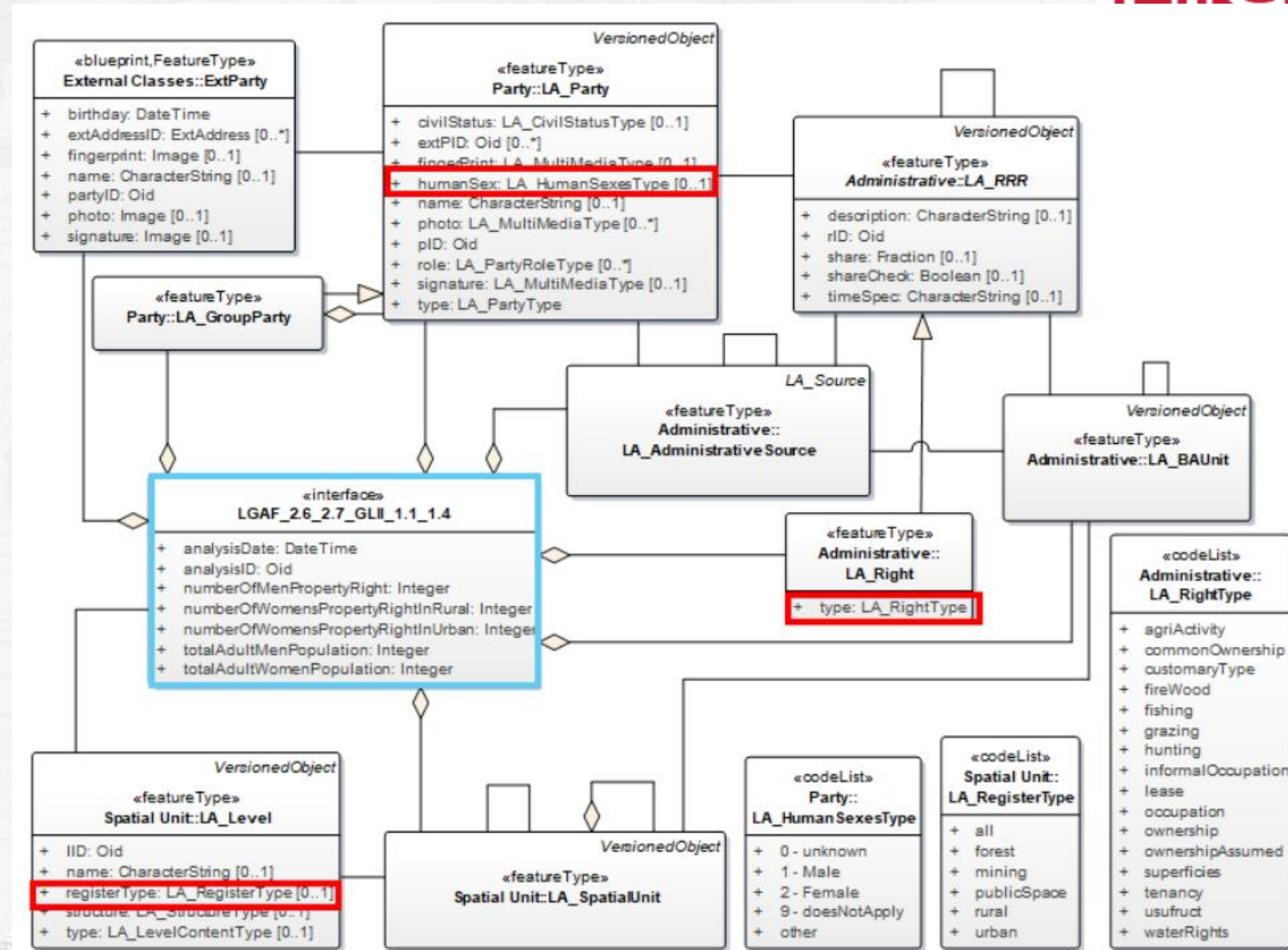

Monitoring indicators through LADM Edition II

LGAF / 8. Speed and predictability of enforcement of restricted land uses (8.2)

The time required to obtain a building permit for a residential dwelling is short.

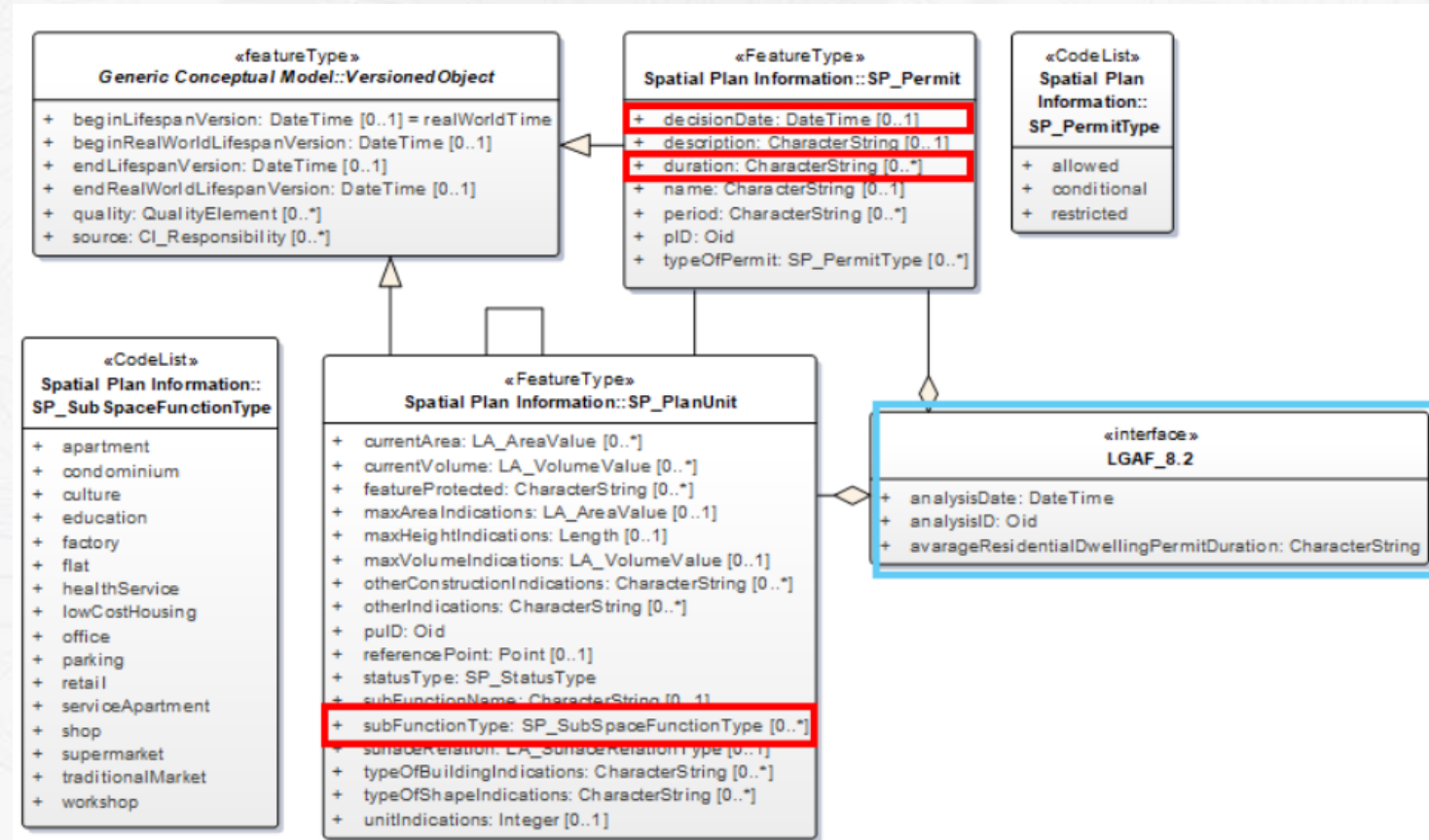

ISO 19152-1 + ISO 19152-5

Monitoring indicators through LADM Edition II

LGAF / 18. Completeness of the land registry (18.2)

The mapping or charting of registry records is complete.

GLI (3.5)

Indicator 3.5
Land area mapped

Proportion of national land areas with rights holders and tenure status identified that are incorporated into cadastral maps / land information systems.

ISO 19152-1 + ISO 19152-2

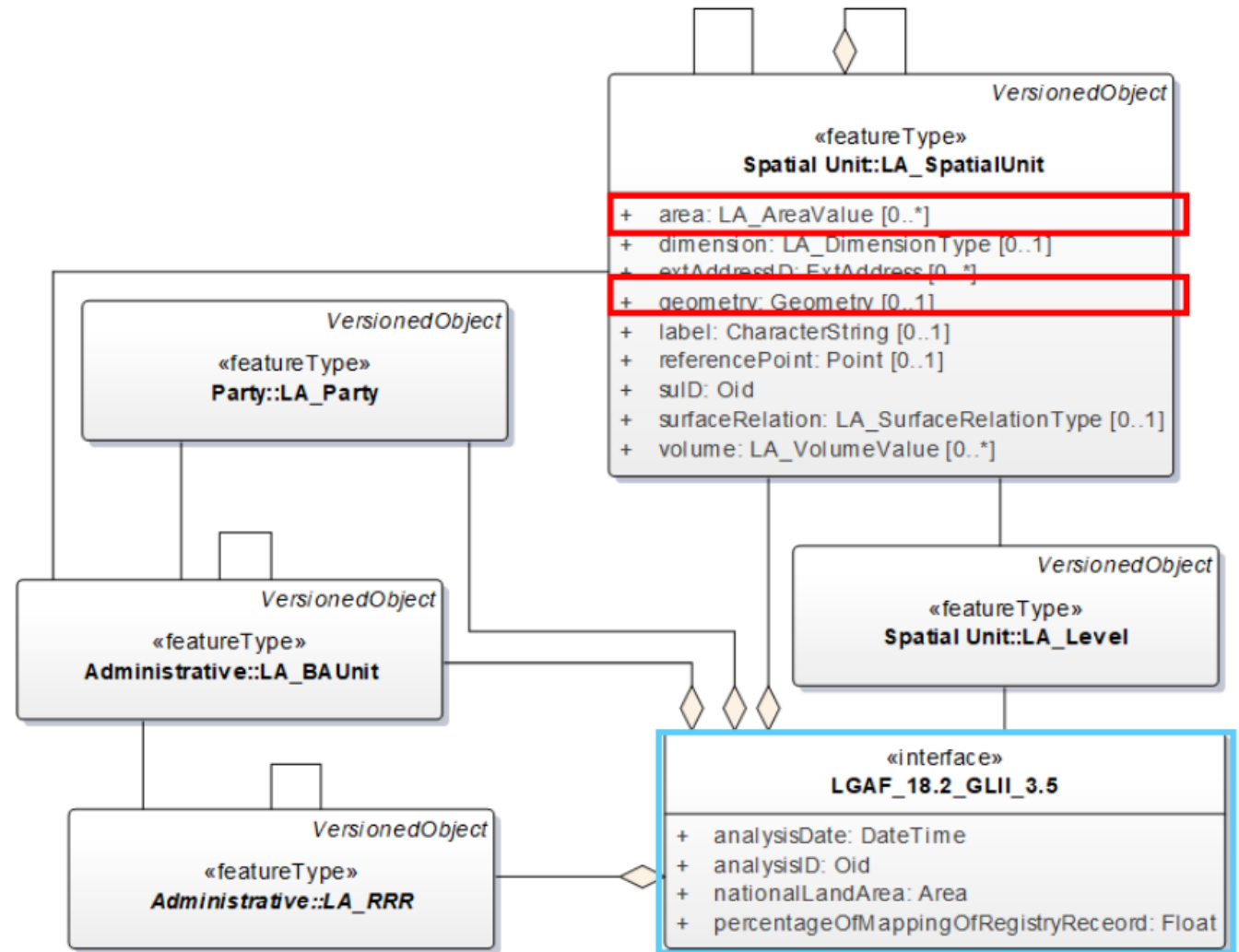

Monitoring indicators through LADM

Edition II

LGAF / 18. Completeness of the land registry (18.3+18.4)

Economically relevant private encumbrances are recorded.

Socially and economically relevant public restrictions or charges are recorded.

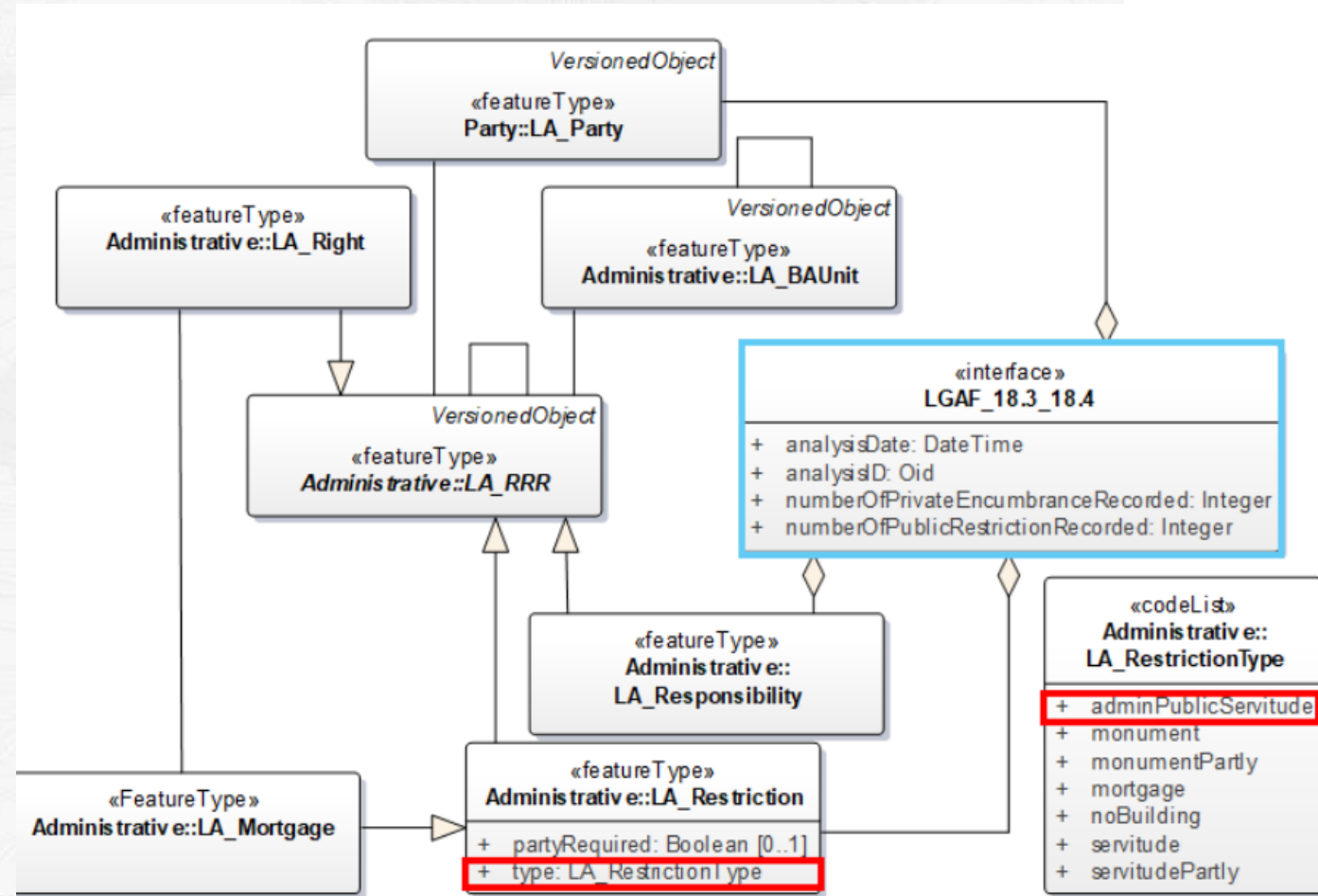

ISO 19152-1 + ISO 19152-2

Monitoring indicators through LADM Edition II

LGAF / 19. Reliability:
registry information is
updated and sufficient
to make meaningful
inferences on
ownership (19.2)

Registry/cadastre information is up-to-date.

ISO 19152-1 +
ISO 19152-2

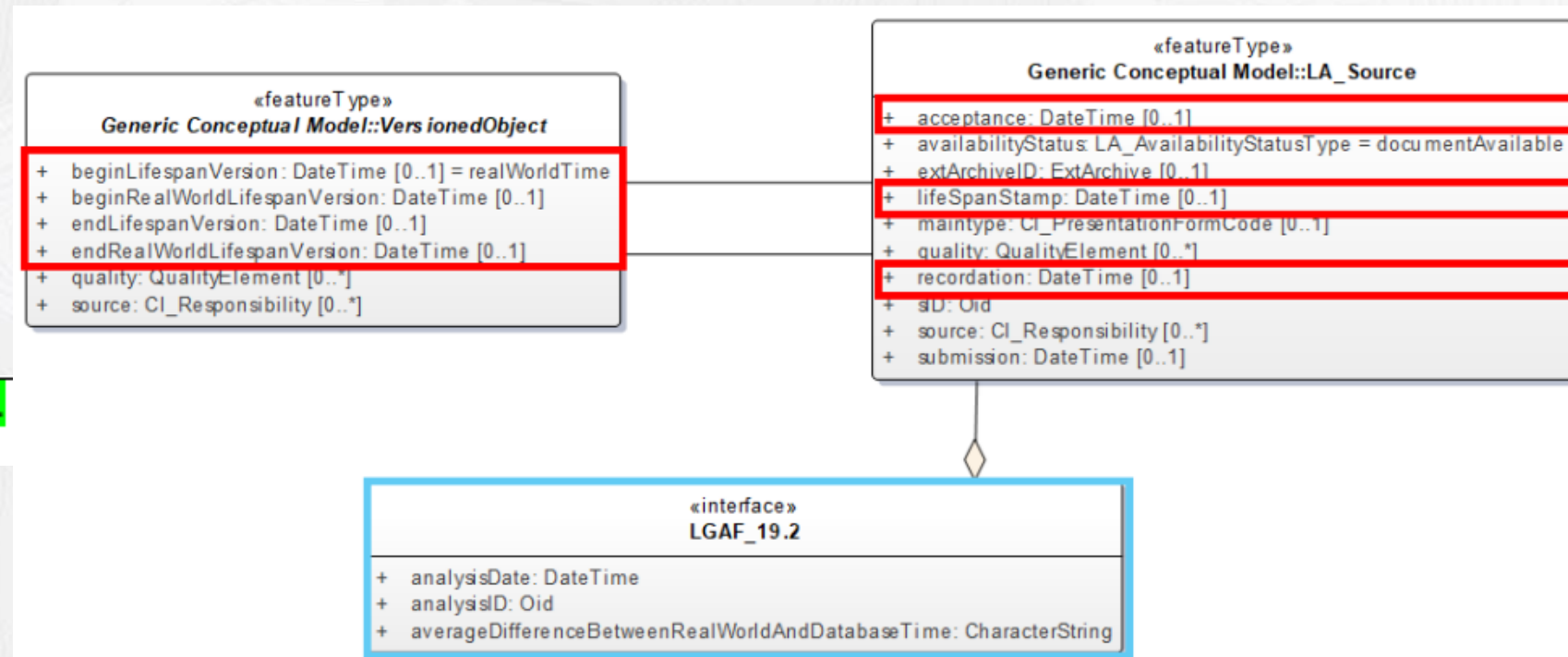

Conclusion

- LGAF

- 10 dimensions → a full computational association with LADM,
- 11 dimensions → a partial computational association,
- 31 dimensions → an indirect association,
- 2 dimensions → partially associated with other standards (ISO 19144-3),
- 55 dimensions are found to be related to a country's national legislation and its implementation.

- GLI

- 3 indicators → a full computational association with LADM,
- 3 indicators → a partial computational association,
- 3 indicators → an indirect association,
- 6 indicators are found to be associated with the national legislation of a country and the implementation of the legislation

Conclusion

- The evaluation of indicators with LADM depends on many situations (e.g. **country implementation, data accuracy, timeliness**, etc.)
- A country, for example, may develop a country profile for **land disputes** based on LADM. However, **indicators related to land disputes are not considered monitorable with LADM in this paper**, as they are not conceptually modeled in LADM.
- The number of **countries reporting to LGAF and GLI is relatively limited**. The number of reporting countries should be improved and LADM indicator modeling can facilitate this.
- Some of the examples in this paper (together with Chen et al. (2024)) could be added to Annex I (Interface Class) of ISO 19152-2.
- Future work: **operations and methods** can be specified to the interface classes to track the performance of LASs in an **automated** and formalized manner.



Thank you!

Abdullah Kara is supported by the FIG Foundation with the FIG LADM Project – Finalization of ISO Standards of LADM. The author would like to express his gratitude to the FIG Foundation for its support

